

# 5RRSV

## Wind Driven Rain Resistant Stationary Louver

Extruded Aluminum

# RELIABLE

### APPLICATION

The 5RRSV is a 5" deep mechanically fastened, extruded aluminum double drainable stationary vertical louver designed to protect air intake and exhaust openings in exterior walls. This louver offers exceptional protection against wind-driven rain under the most severe conditions. This louver is designed with a drainable gutter system channeling water from the blades to downspouts in the jambs, where water is exhausted out of the front of the louver.

### STANDARD CONSTRUCTION

<b>Frame</b>	5" (127) deep, 6063T6 extruded aluminum with .080" (2.03) nominal wall thickness.
<b>Blades</b>	6063T6 extruded aluminum .060" (1.52) nominal wall thickness. Blades are mounted vertically, sightproof and spaced approximately 2" (51) center to center.
<b>Screen</b>	1/2" x .063" (13 x 1.6) square mesh aluminum bird screen in removable frame. Screen adds approximately 1/2" (13) to louver depth.
<b>Extended Sill</b>	.080" (2.03) formed aluminum.
<b>Finish</b>	Mill.
<b>Minimum Size</b>	12"w x 12"h (305 x 203).
<b>Approximate Shipping Weight</b>	7 lbs. per sq. ft. (34.2 kg/m <sup>2</sup> ).
<b>Maximum Single Section Size</b>	Single sections shall not exceed 120"w x 90"h (3048 x 2286) or 90"w x 120"h (2286 x 3048). Lifting lugs provided on louvers 48" x 72" (1219 x 1829) and larger. Louvers larger than the maximum factory assembly size will require field assembly of smaller sections.

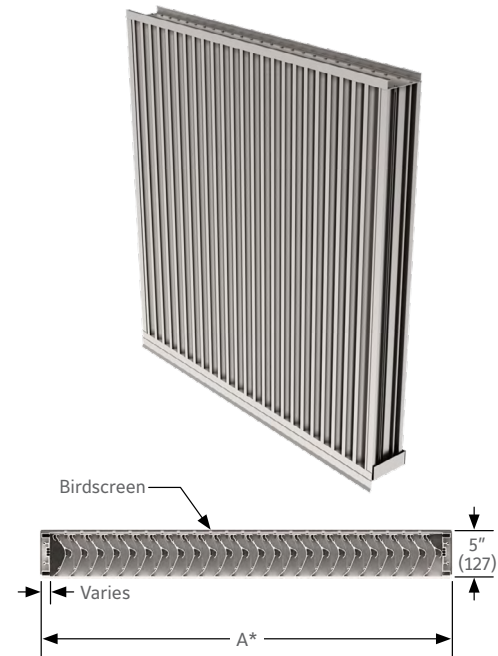

### FEATURES

- 43% free area
- Closely spaced vertical blades prevent the penetration of wind-driven rain, reducing damage and additional operating expenses
- Published performance ratings based on testing in accordance with AMCA Publication 511
- Pressure drop of .18" w.g. (44.8 Pa) at 989 FPM Free Area Velocity
- Withstands 30 psf (1.44 kPa) windload
- Aluminum construction for low maintenance and high resistance to corrosion
- Mechanically Fastened Construction
- Extended Sill with End Dams

### OPTIONS

- Extended sill
- Sleeve
- Blankoff Panel
- Hinged frame
- Front or rear security bars
- Filter racks
- Installation angles
- A variety of bird and insect screens
- Optional finishes at additional cost: Prime coat, 50% PVDF (modified fluoropolymer), Epoxy, Pearledize 50 and 70, 70% PVDF, Clear and Color Anodized finishes. (Some variation in anodize color consistency is possible)

All variations are available at additional cost.  
Consult Reliable for other special requirements.

Note:

- Dimensions in inches, parenthesis ( ) indicate millimeters.
- Units can be furnished actual size or with size deducts.

# FREE AREA GUIDE

Free Area Guide shows free area in ft<sup>2</sup> and m<sup>2</sup> for various sizes of 5RRSV.

		Width – Inches and Meters																			
		12	18	24	30	36	42	48	54	60	66	72	78	84	90	96	102	108	114	120	
		0.30	0.45	0.60	0.75	0.90	1.05	1.20	1.35	1.50	1.65	1.80	1.95	2.10	2.25	2.40	2.55	2.70	2.85	3.00	
Height – Inches and Meters	12	0.30	0.15	0.26	0.37	0.48	0.59	0.74	0.85	0.96	1.07	1.18	1.30	1.44	1.55	1.67	1.78	1.89	2.00	2.15	2.26
		0.01	0.02	0.03	0.04	0.05	0.07	0.08	0.09	0.10	0.11	0.12	0.13	0.14	0.16	0.17	0.18	0.19	0.20	0.20	0.21
	18	0.45	0.32	0.56	0.80	1.04	1.29	1.61	1.85	2.09	2.33	2.57	2.81	3.13	3.37	3.62	3.86	4.10	4.34	4.66	4.90
		0.03	0.05	0.07	0.10	0.12	0.15	0.17	0.19	0.22	0.24	0.26	0.29	0.31	0.34	0.36	0.38	0.40	0.43	0.43	0.46
	24	0.60	0.49	0.87	1.24	1.61	1.98	2.47	2.84	3.22	3.59	3.96	4.33	4.82	5.19	5.57	5.94	6.31	6.68	7.17	7.54
		0.05	0.08	0.12	0.15	0.18	0.23	0.26	0.30	0.33	0.37	0.40	0.45	0.48	0.52	0.55	0.59	0.62	0.67	0.67	0.70
	30	0.75	0.67	1.17	1.67	2.17	2.67	3.34	3.84	4.34	4.84	5.34	5.85	6.51	7.01	7.52	8.02	8.52	9.02	9.69	10.19
		0.10	0.16	0.22	0.27	0.33	0.39	0.45	0.51	0.57	0.63	0.68	0.74	0.80	0.86	0.92	0.98	1.04	1.10	1.10	1.15
	36	0.90	0.84	1.47	2.10	2.73	3.37	4.21	4.84	5.47	6.10	6.73	7.36	8.20	8.33	9.47	10.10	10.73	11.36	12.20	12.83
		0.08	0.14	0.20	0.25	0.31	0.39	0.45	0.51	0.57	0.63	0.68	0.76	0.82	0.88	0.94	1.00	1.06	1.13	1.13	1.19
	42	1.05	1.01	1.78	2.54	3.30	4.06	5.07	5.83	6.60	7.36	8.12	8.88	9.89	10.65	11.42	12.18	12.94	13.70	14.71	15.47
		0.09	0.17	0.24	0.31	0.38	0.47	0.54	0.61	0.68	0.76	0.83	0.92	0.99	1.06	1.13	1.20	1.27	1.37	1.37	1.44
	48	1.20	1.19	2.08	2.97	3.86	4.75	5.94	6.83	7.72	8.61	9.50	10.40	11.58	12.47	13.37	14.26	15.15	16.04	17.23	18.12
		0.11	0.19	0.28	0.36	0.44	0.55	0.64	0.72	0.80	0.88	0.97	1.08	1.16	1.24	1.33	1.41	1.49	1.60	1.60	1.69
	54	1.35	1.36	2.38	3.40	4.42	5.45	6.81	7.83												
		0.13	0.22	0.32	0.41	0.51	0.63	0.73													
60	1.50	1.53	2.69	3.84	4.99	6.14	7.67	8.82													
	0.14	0.25	0.36	0.46	0.57	0.71	0.82														
66	1.65	1.71	2.99	4.27	5.55	6.83	8.54	9.82													
	0.16	0.28	0.40	0.52	0.64	0.79	0.91														
72	1.80	1.88	3.29	4.70	6.11	7.53	9.41	10.82													
	0.17	0.31	0.44	0.57	0.70	0.88	1.01														
78	1.95	2.05	3.60	5.14	6.68	8.22	10.27	11.81													
	0.19	0.33	0.48	0.62	0.76	0.96	1.10														
84	2.10	2.23	3.90	5.57	7.24	8.91	11.14	12.81													
	0.21	0.36	0.52	0.67	0.83	1.04	1.19														
90	2.25	2.40	4.20	6.00	7.80	9.61	12.01	13.81													
	0.22	0.39	0.56	0.73	0.89	1.12	1.28														
96	2.40	2.57	4.51	6.44	8.37	10.30	12.87	14.80													
	0.24	0.42	0.60	0.78	0.96	1.20	1.38														
102	2.55	2.57	4.81	6.87	8.93	10.99	13.74	15.80													
	0.26	0.45	0.64	0.83	1.02	1.28	1.47														
108	2.70	2.92	5.11	7.30	9.49	11.69	14.61	16.80													
	0.27	0.48	0.68	0.88	1.09	1.36	1.56														
114	2.85	3.09	5.42	7.74	10.06	12.38	15.47	17.79													
	0.29	0.50	0.72	0.94	1.15	1.44	1.65														
120	3.00	3.27	5.72	8.17	10.62	13.07	16.34	18.79													
	0.30	0.53	0.76	0.99	1.22	1.52	1.75														

# ■ PRESSURE DROP

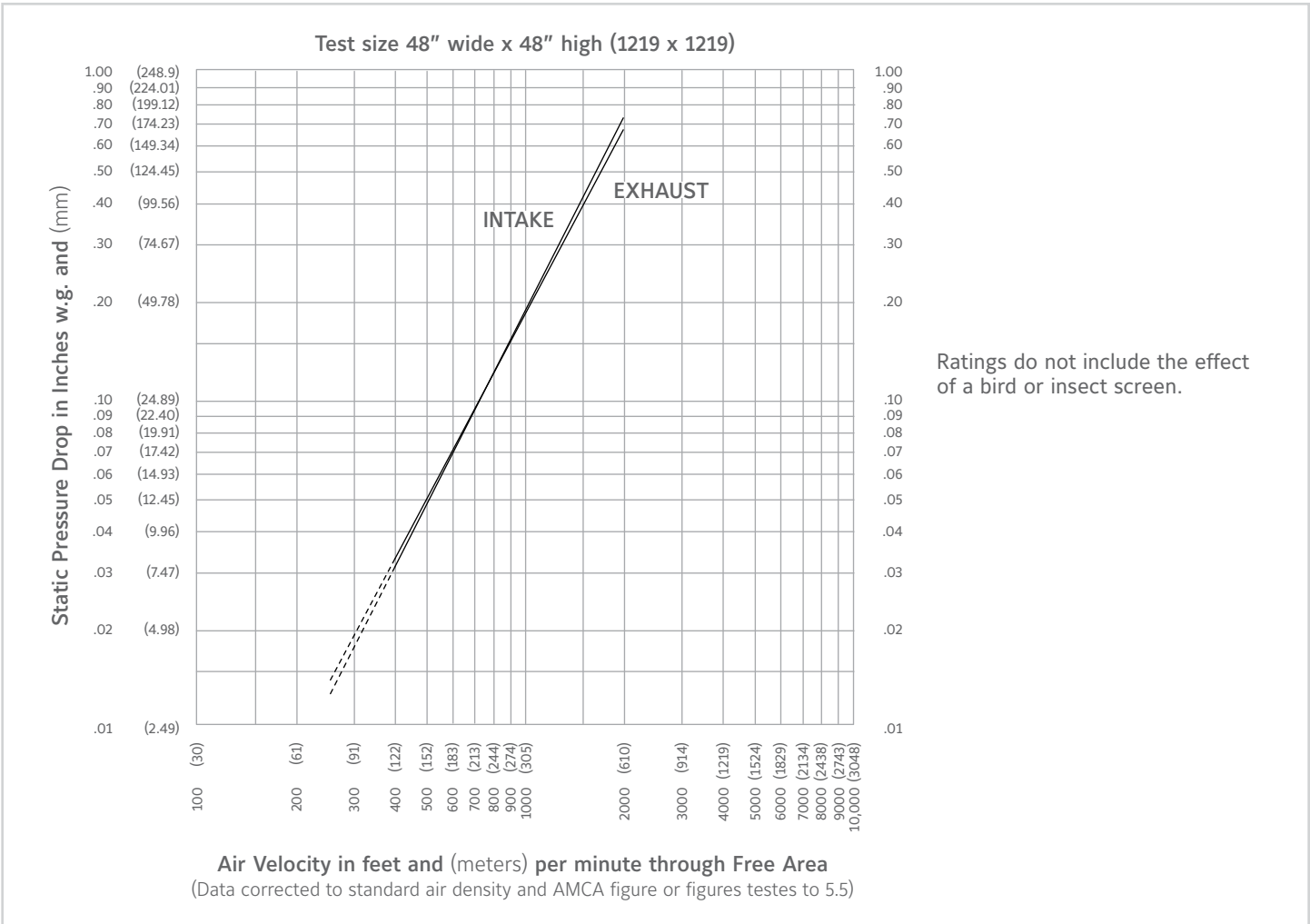

## WIND-DRIVEN RAIN PERFORMANCE AMCA 500-L WIND-DRIVEN RAIN TEST

Test size is 1m x 1m (39" x 39") core area, 1.05m x 1.08m (41 1/4" x 42 5/16") nominal. Free Area of test louver is 4.71 ft<sup>2</sup> (.44m<sup>2</sup>).

Wind Velocity mph (kph)	Rain Fall Rate In./hr. (mm/hr.)	Core Velocity <sub>1</sub> fpm (m/s)	Airflow cfm (m <sup>3</sup> /min)	Free Area Velocity <sub>2</sub> fpm (m/sec.)	Effectiveness Ratio	Class <sub>3, 4</sub>	Discharge Loss Class <sub>5</sub> Intake
29 (46.4)	3" (76)	979 (5)	10,537 (298)	2,237 (11.4)	100%	A	3
50 (80.5)	8" (203)	989 (5)	10,650 (302)	2,261 (11.5)	100%	A	3

### NOTES:

1. Core area is the open area of the louver face (face area less louver frames). Core Velocity is the airflow velocity through the Core Area of the louver (1m x 1m). 5 m/s is the maximum core velocity utilized in this test.
2. Free Area of test size is calculated per AMCA standard 500-L.
3. Wind Driven Rain Penetration Classes:

#### Class Effectiveness

A	1 to .99
B	0.989 to 0.95
C	0.949 to 0.80
D	Below 0.8

4. The 5RRSV provides class A performance at all velocities up to and including 5 m/s core velocity.
5. Discharge Loss Coefficient is calculated by dividing a louvers actual airflow rate vs. a theoretical airflow for the opening. It provides an indication of the louver's airflow characteristics.

#### Class Discharge Loss Coefficient

1	0.4 and above
2	0.3 to 0.399
3	0.2 to 0.299
4	0.199 and below

(The higher the coefficient, the less resistance to airflow.)

6. The AMCA Wind Driven Rain Test is performed in a laboratory environment and incorporates controlled wind, water and system airflow effects. In actual field installations, storms may create conditions not considered by the AMCA test. Penthouse and similar applications where wind can pass through multiple louvers in an enclosure is another condition that is not simulated by AMCA tests. These applications can create elevated water penetration rates through any louver. Because of these uncontrolled situations it is recommended that provisions to manage water penetration through louvers be included in the building design.



Reliable® Company certifies that the 5RRSV louver shown herein is licensed to bear the AMCA Seal. The ratings shown are based on tests and procedures performed in accordance with AMCA Publication 511 and comply with the requirements of the AMCA Certified Ratings Program. The AMCA Certified Ratings Seal applies to air performance ratings and wind driven rain ratings only.

# TYPICAL INSTALLATION DETAILS

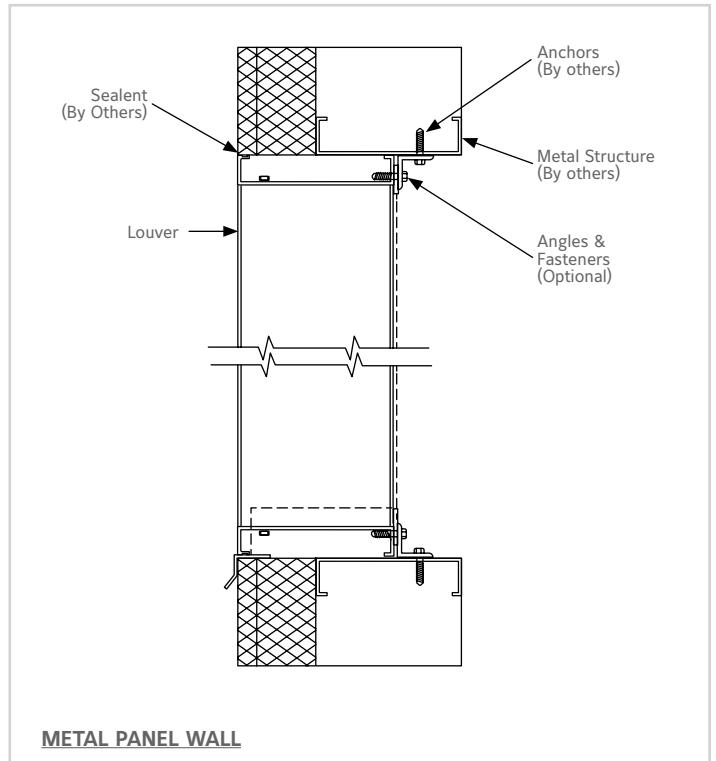
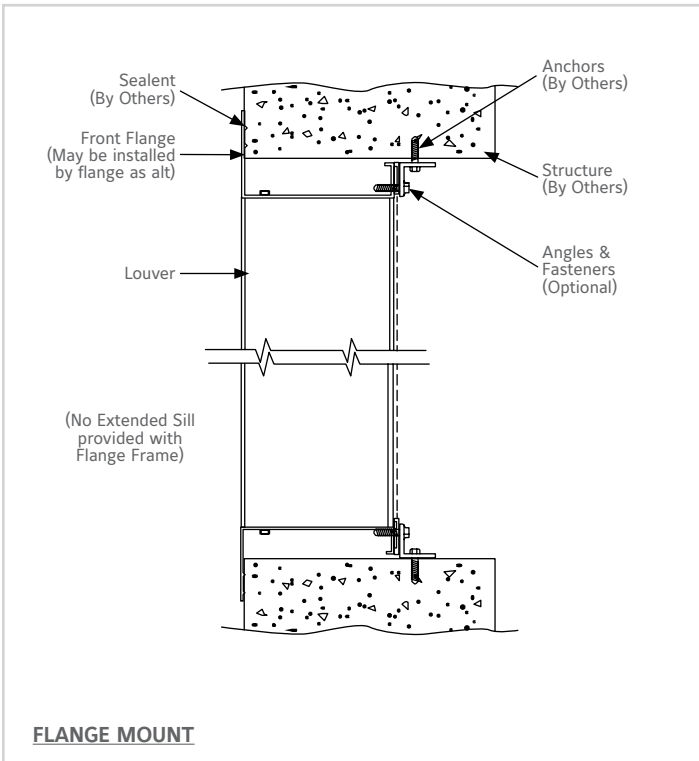
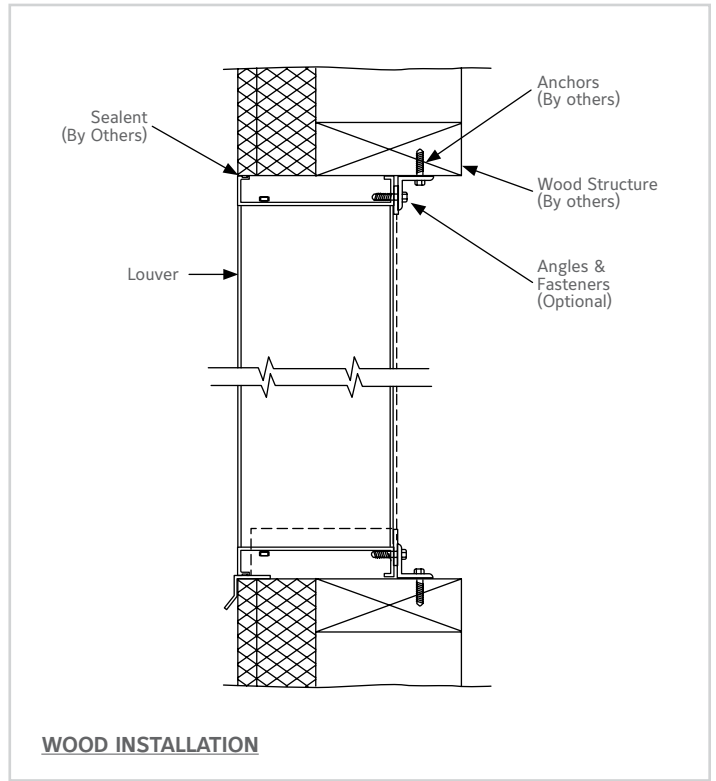
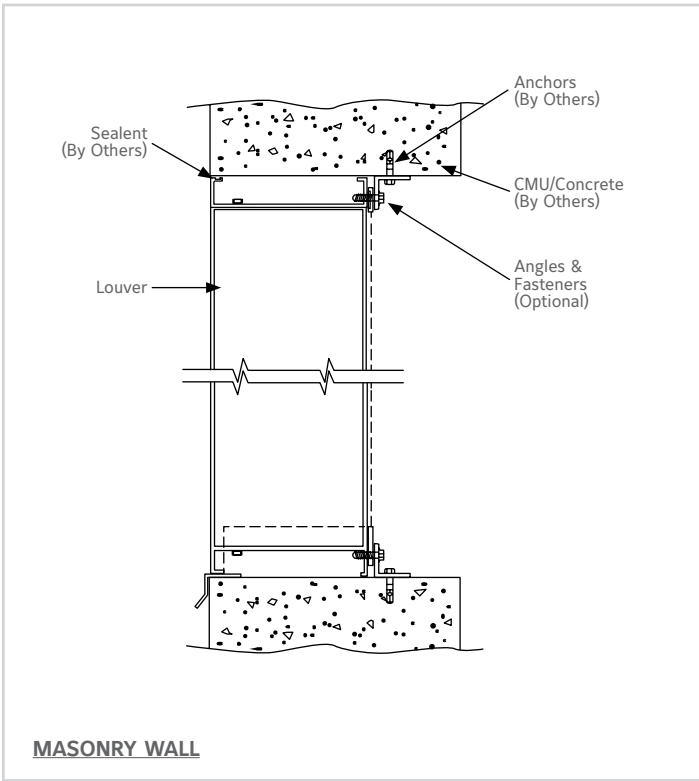

Options available at additional cost.

## SUGGESTED SPECIFICATION

Furnish and install louvers as hereinafter specified where shown on plans or as described in schedules. Louvers shall possess stationary vertical blades designed to prevent the penetration of wind driven rain. Louver blades shall be contained within a 5" (127) frame. Extended sill shall be provided to capture and drain water to exterior of building. Louver components (heads, jambs, sill and blades) shall be factory assembled by the louver manufacturer. Louver sizes too large for shipping shall be built up by the contractor from factory assembled louver sections to provide overall sizes required. Louvers shall withstand a wind load of 30 lbs. per sq. ft. (1.44 kPa) (specifier may substitute any loading required).

Louvers shall be Reliable® Model 5RRSV extruded 6063T6 aluminum alloy construction as follows:

Frame: 5" (127) deep, 6063T6 extruded aluminum with .080" (2.0) nominal wall thickness.  
Blades: .063" (1.6) wall thickness, installed vertically on approximately 2" (51) centers.  
Extended Sill: .081" (2.1) wall thickness, with upturned side panels to prevent water leakage.  
Screen: 1/2" x .063" (13 x 1.6) square mesh aluminum bird screen in removable frame.  
Finish: Mill.

### LINKS TO IMPORTANT DOCUMENTS

Document Title
Finishes and Color Guide
Limited Warranty Document



1300 Enterprise Road, P.O. Box  
580, Geneva, Alabama 36340  
Tel: 334-684-3621  
Tel: 800-624-3914  
Fax: 800-508-1469